

Sanisub 800 Rainkit

The Sanisub 800 Rainkit is a pumping kit for clear water for pumping flood water from living rooms or cellars. This pump kit can raise water up to 11 m with a particle size of 20 mm without the drain by placing the pump on the feet provided. This rainwater lifting kit consists of 2 pumps to be mounted on a stainless steel frame. The pumps work alternately. The pumps are pre-assembled.



PERFORMANCE

- Max. Head: 11 m
- Max. Flow rate: 15 m³/h

PRODUCT FEATURES & BENEFITS

- Particle size of 20 mm without the drain by placing the pump on the feet provided
- Lift height of 11 m
- 2 Sanisub 800 pumps
- Alternating operation of the pumps
- Non-return valves integrated into the pumps
- Stainless steel frame with overflow filling
- Pre-assembled pipes

PACKAGING

Control box, PVC pipe, stainless steel frame, 2 Sanisub 800 pumps, alarm float



CURVE

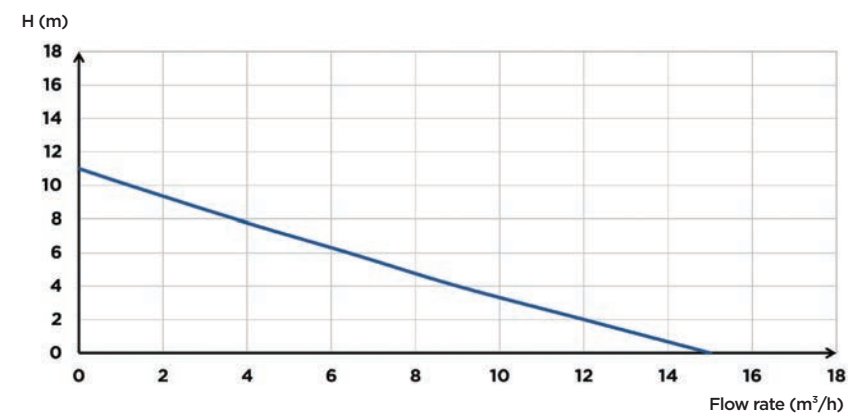

DIMENSIONS

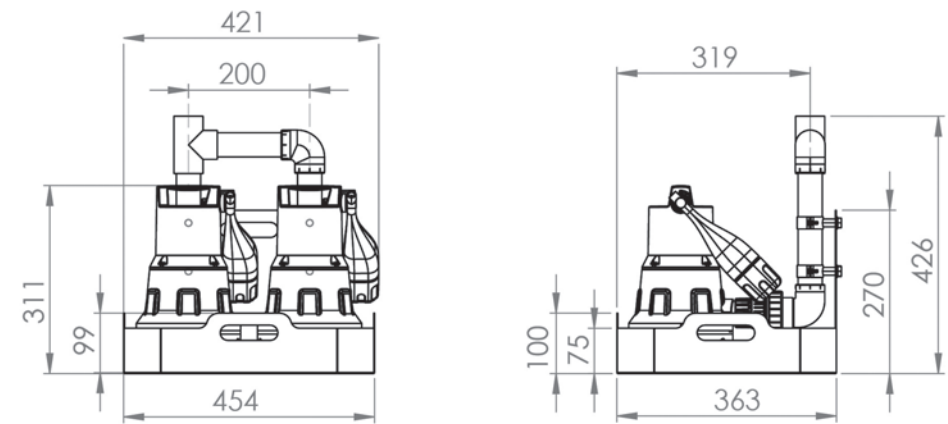

	Sanisub 800 Rainkit
Material	
Shaft	Stainless steel
Pump housing	PP GF
Seal	NBR
Motor housing	Stainless steel
Impeller	PA 6 GF
Electrical features	
Voltage (V)	230
Frequency (Hz)	50-60
Power consumption P1 (W)	800
Power output P2 (W)	600
Revolutions per minute (RPM)	2800
Electrical class	I
Immersion depth (m)	7
Power cable: Length (m)	10
Hydraulics	
Max. Head (m)	11
Max. Flow rate (m ³ /h)	15
Discharge diameter G (inch)	1 1/4
Discharge diameter ext. (mm)	40
ON Level /OFF level (mm)	250/130
Particle size (mm)	20
Max. Temperature of the pumped liquid (5 min max)	70°C
Type of impeller	multi-channel
Type of activation	float
Identification and logistics	
Gross weight (kg)	24
Barcode	3308815096568
Product code	33106